

Big Data Development of Tourism Resources Based on 5G Network and Internet of Things System

Haifeng Gao^{a,b}

^a International College, National Institute of Development Administration, Bangkok, 10240, Thailand

^b University of Finance and Economics, Nanning, Guangxi, 530000, China

ARTICLE INFO

Keywords:

Tourism Resources
Big data Analysis
5G network and IoT
Field Programmable Gate Array (FPGA)

ABSTRACT

With the improvement of information development level, the development speed of big data is also very fast, more and more fields are using big data to manage. Different departments and enterprises get more information from data, and big data is used more and more frequently. However, it is more and more contradictory to the demand for big data that the traditional data technology platform and system can not meet the increasing demand of big data. These traditional data systems and data platforms usually have the disadvantages of slow response, small data memory and certain uncertainty of recorded content. Therefore, big data is developed and studied to increase the volume and accuracy of data systems and platforms. This paper studies the development and utilization of big data by analyzing neural network. The main purpose is to make the big data system and platform more perfect. Some technical requirements and program requirements in big data also gradually adapt to the consistency of data platform and data system. The improvement of people's living standard also promotes the rapid development of tourism. The inclusion of tourism in the Internet of things has become a new technological requirement. Intelligent tourism has been recognized and used by more and more people. Because the Internet of things has a very powerful amount of information, more and more people, especially young people, prefer to travel intelligently through the Internet of things. This paper points out that tourists choose to use machine classification through the Internet of things. This classification can help tourists make better choices. The accuracy of this method is verified by experiments.

1. Introduction

In the Internet, the proportion of the Internet of things is increasing, and in the future development of the Internet, the Internet of things will play a greater role. The wide use of the Internet of things makes people choose to use the Internet of things not only in tourism, but also in online medical treatment. The Internet of things will have a significant impact on all aspects of people's lives. At the same time, enterprises, especially tourism enterprises, will put the focus of development into the Internet of things, which will make enterprises develop rapidly. The scene real-time online and the clear and intelligent scene space in the Internet of things make people take the intelligent tourism of the Internet of things as the first choice when traveling. Because there will be artificial fraud and other bad phenomena in many tourist attractions, intelligent tourism can help tourists better understand the tourist attractions, and give tourists all kinds of information they need to be fully displayed. The purpose of our system is to provide more reasonable and scientific information and services to different tourist groups, so as to innovate the

tourism development model.

The development of cloud services in the network also enables us to better search for all kinds of information needed. Effective integration of GPS and smartphones and 5 G networks allows people to experience new travel patterns through mobile phones. As the 5 G system matures and gradually applies to people's real life, the prospect of intelligent tourism is more beautiful. Since the transmission speed of 5 G is faster and the accuracy of transmission is higher, the tourism industry can be upgraded while the 5 G is popularized. The integration of 5 G technology with artificial intelligence, AR and so on, and the establishment of corresponding applications promote the development of tourism. It will also benefit more enterprises and people.

2. Literature Survey

There is a real-time tracking system for local air quality in the Azure and Aeon hybrid platform developed by Microsoft. The use of this system has led to the rapid development of tourism in the Azores region.

E-mail address: gaohaifeng2288@163.com.

<https://doi.org/10.1016/j.micpro.2020.103567>

Received 10 November 2020; Received in revised form 25 November 2020; Accepted 30 November 2020

Available online 2 December 2020

0141-9331/© 2020 Elsevier B.V. All rights reserved.

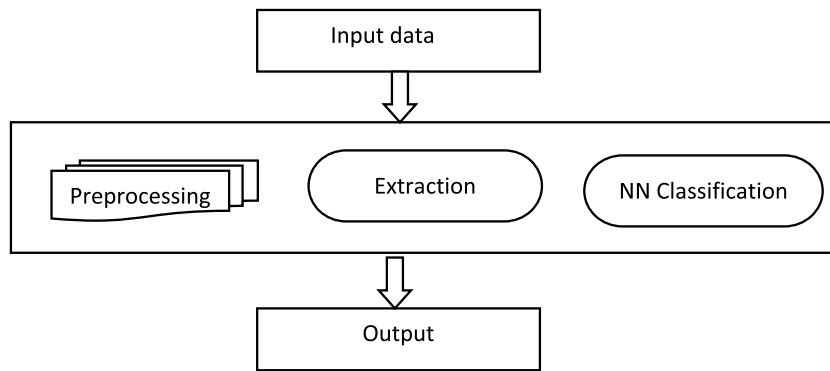

Figure 1. Proposed Block Diagram

Investment in sustainable tourism [1,2] is also increasing. The Internet of things is a new communication technology rising in recent years. It enables users and services to make a seamless connection. By intelligent operation and fast storage for different users of different needs [3,4] can provide precision services.

RFID and shopping systems can provide more accurate information about nearby shopping malls and even help blind people shop [5]. Through this information, guide people to where they need them. This software [6] can better realize intelligent tourism service. Park managers also provide better intelligent services to parks through the Internet of things. During the previous research of the Internet of things system, more emphasis was placed on the deployment of the 2 D of the Internet of things system, which could not realize the difference of three-dimensional terrain. At the same time, it does not include the role of service [7,8] in the Internet of things, and the powerful benefits of intelligent services to the Internet.

The Internet of Things is essential, including preparing innovative technologies and creating connections with physical artifacts in information technology. Recover through smart devices leads to innovative interpretations and uses hidden cultural heritage values to connect memories of choice and historical stories [9, 10]. Evaluation allows managers to equip intelligent services and improved management efficiency and tourism satisfaction and their tourist attractions. However, there are some recognition criteria for realizing tourist attractions based on the Internet of Things. The general method of using mean values to replace multiple rating scores is not sufficient [11, 12].

As spatial information became more widespread, the rapid

development and high technology of such information and communication technologies, the Internet of Things, and big data applications became more diversified. It plays an essential role in planning smart cities and smart homes [13, 14]. This work proposes an empirical (experience quality) evaluation method based on multiple regression analysis for the Internet of Things' quality. First, the type of IoT application that the analysis is working on determines the quality of service (QoS) with user experience quality parameters and collected sample data [15].

3. Materials and Methods

In literary research, researchers have collected previous research material and are used to provide reference reports for their research. In the field survey, field observations are conducted to help researchers create analytical applications. The second step is to collect the data for creating the application. The data collected is collected by interviewing museums and museum records. Data collected in the form of text and images are collected. Also, the proposed system structure is shown in figure 1.

The third stage is the design of neural network classifier. Neural network is one of the most commonly used application software. Through the research of various graphics, the simulation activities can be better displayed in the graphics.

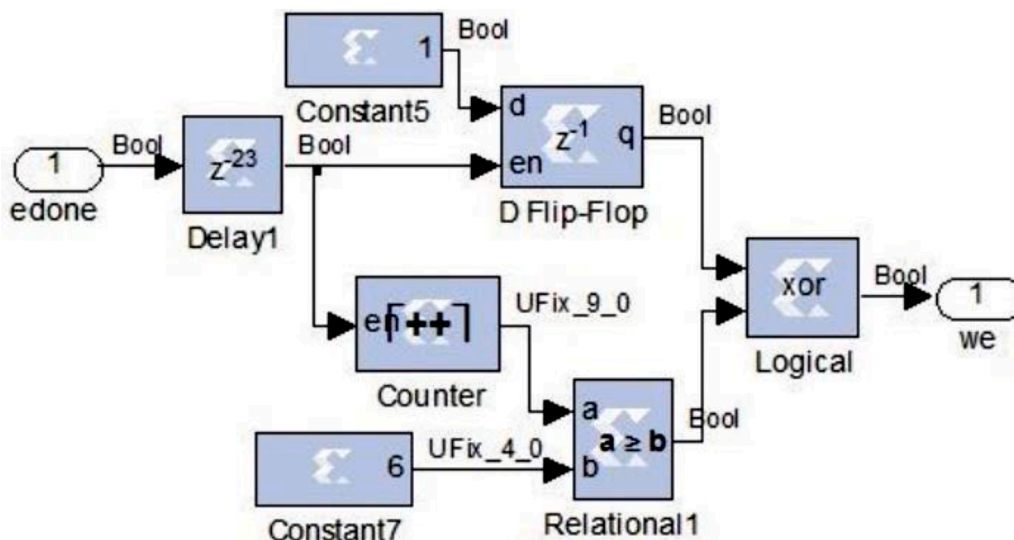

Figure 2. Data processing Circuit

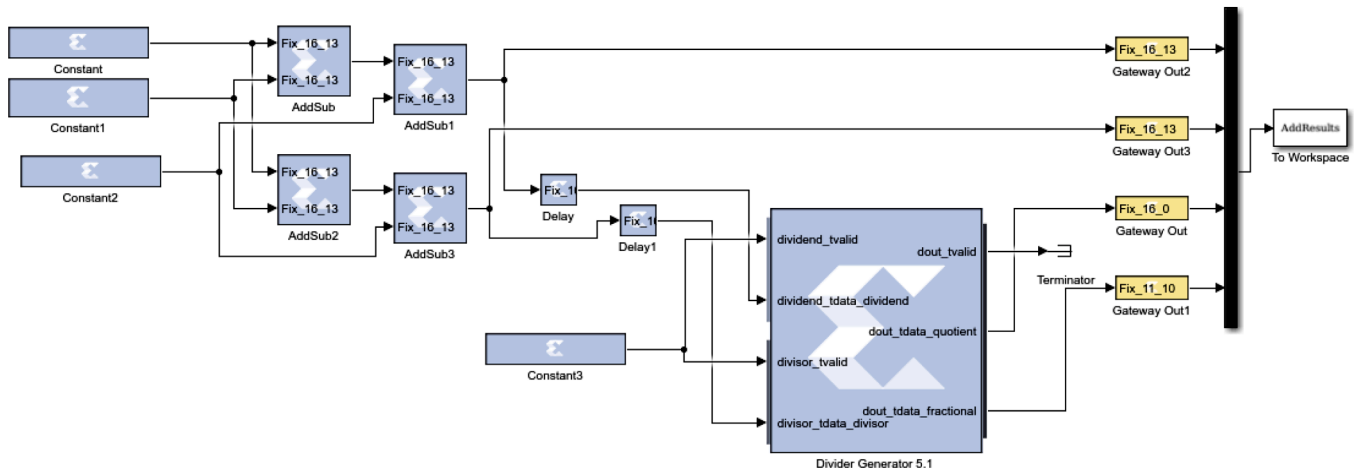

Figure 3. Network data extraction

3.1. Data Preprocessing

Tourism managers use the Internet of things to make tourism develop rapidly. This also makes tourism a major user of information technology. With the development of information technology, services and related facilities are more applied and popularized, thus making the relationship between tourists and service providers closer. Tourists can access all kinds of information through the Internet of things and information technology, so as to meet their needs and where they want to travel. For scenic spots, the scenery of scenic spots is easier to display and express through images. For example, the hotel's environmental hygiene, room facilities and so on can be displayed on the Internet by image or photo. Some tourist attractions such as promotional activities, can also be promoted through the Internet around the world. Advertising promotion and publicity has been unprecedented expansion. For the system data mining, can also make tourists and tourism managers to establish a rapid and convenient relationship. With the increase of tourism personnel and tourism data, tourism related industries or departments will also produce more data information.

Figure 2 shows the median filter circuit is mainly used to generate some random noise that reduces noise in the data and reduces the filter, which has good noise reduction capabilities. The quality of data text

preprocessing has been improved compared to the input system. The selected file starts the initialization phase here from the text portion of the educational resource. Preprocessing initializes from the text part of the relational statement analysis. Removes other unrelated terms that depend on the relationship identified as the stop word.

3.2. 5G Network data Extraction

With the development of Internet-based information acquisition technology, the Internet of Things will begin the third wave of industrialization. The development and application of the Internet of Things and one of the essential strategic measures to solve economic problems is a new trend of globalization that will lead us in the new information age. The same applies to implementations in travel, entertainment and business applications. This can increase each link's information perception's depth and breadth and provide reliable support for the tourism industry. People can access and use intuitive and convenient services. This means that comprehensive and well-designed services will play an essential role in future cloud services, and the circuit is shown in figure 3.

Not only can you apply the Internet of Things in tourist areas, but you can also comply with the concept of "low carbon" and significantly

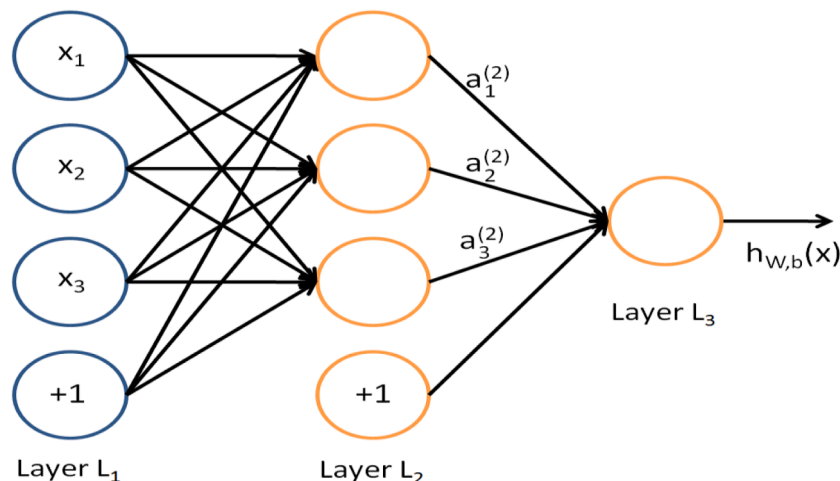

Figure 4. Neural Network Layer

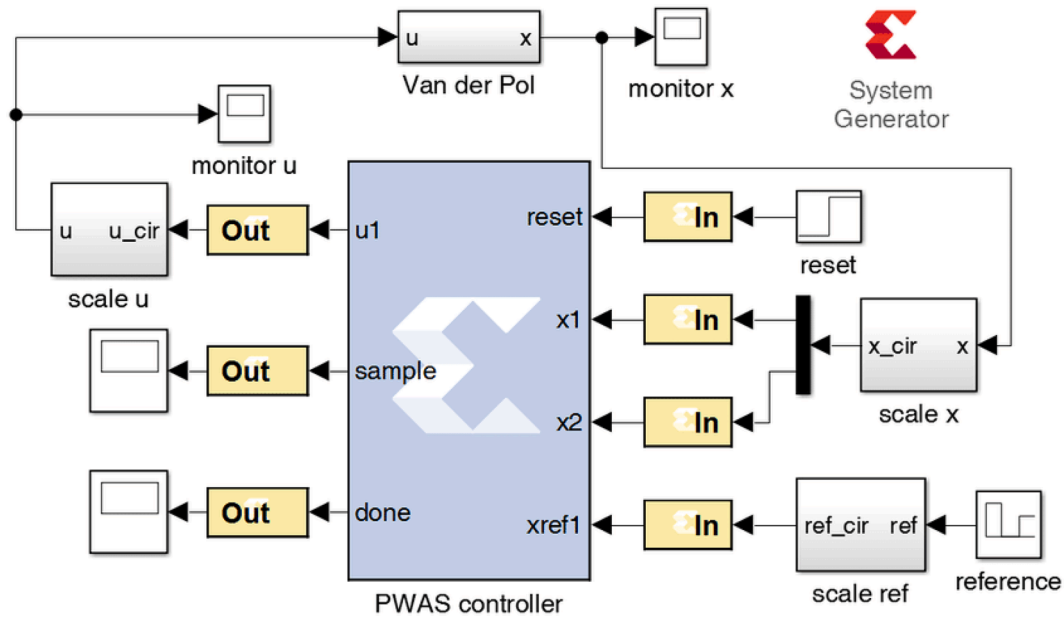

Figure 5. Proposed FPGA circuit

improve your management efficiency. Potential tourism IoT applications include wildlife surveillance, tourism information services, hotel services, tourism marketing, mountaineering, and all-weather surveillance monitoring and tracking, ocean surveillance, bird and plant species. The Internet of Things can monitor and track wildlife in many ways through sensors transplanted into animals, such as workers visiting, sending data to servers and tracking animal movements. Features that can be achieved with smart Internet of Things travel applications such as travel management, ticket management, passenger flow management, information gathering, security monitoring and environmental monitoring. The statistical analysis also makes it easy to implement IoT in your system with statistical reporting and comprehensive management.

3.3. Neural Network Classification

Data mining is primarily a common and essential application that involves predictive models that can be further divided into two categories. Classification means that the target variable is essentially a qualitative prediction. Estimates, on the other hand, essentially refer to quantitative predictions of target variables. Predictive modeling attempts typically predict the objective variable based on one or more input variables. For example, through neural networks, travelers can be more detailed planning. Forecast according to the age, income and expected travel expenses of tourists. This makes tourists travel more targeted. Neural networks can be seen as substances like the human brain that can build a highly connected neuronal system. Through this system, decisions are predicted. Neural networks can be divided in detail by inputting specific data variables through exclusivity and targeting

specific service target objects. Finally, some items are combined in the form of data to make the data graphics more intuitive and more convenient to understand the contents of prediction.

Interactions and cooperation between humans and smart machines are essential for the formation of our future society. But many of the problems humanity faces are often very complex uncertainties and open ends. Human intervention in machines has been consistent throughout these systems' development as an arbitrator for human intelligent machines' ultimate goal as show in Figure 4.

3.4. FPGA

FPGA integration contains matrix blocks, which can allow the reconstruction of linked applications of interconnected blocks, and can also configure logical modules. As a result, the wiring in FPGA integration has complex and sequential functions, so that each digital system can be connected independently and effectively, and it is more convenient to realize the digitization of digital system. opportunity algorithms exist in FPGA integration systems, which can customize the system structure, while mining data algorithms provide data support for many algorithms. FPGA integrated hardware acceleration is more conducive to data mining algorithm.as shown in Figure 5.

High-level language and synthesis tools development and software and hardware co-design methods can make designing an FPGA easier. With advances in FPGA technology in terms of logic resources, FPGA platforms are more often used in data mining applications and provide higher performance computing blocks as the devices grow together. Expected to be used for general calculations.

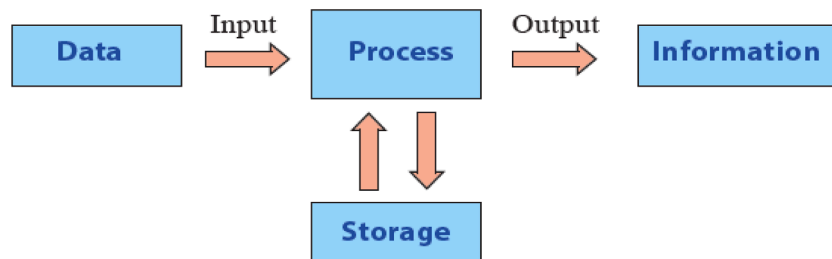

Figure 6. IoT structure

Table 1
Proposed FPGA Implementation

parameters	PSO	SVM	NN
Power supply (w)	24	19	8
latches	365	493	516
Slice	241	377	458
Accuracy (%)	89.8%	91.5%	98.7%

3.5. IoT Technology

As an important part of the development of the Internet, the Internet of things makes the network infrastructure operate around the world by self-configuration of communication protocols. The Internet of things can make it easier for them to communicate with each other, so that they can operate and identify intelligently. Achieving various goals through unique solutions such as telephone, positioning, tracking, and monitoring and management functions. On the Internet of Things, everything can be exchanged without manual intervention. First, the Internet of Things is the Internet; its expansion, core and foundation is still the Internet. Second, the Internet of Things' scope has expanded the exchange of information to make it all happen: in fact. The Internet of Things has two meanings.

Figure 6 shows the structure of the Internet of things. This structural system of the Internet of things has become a new communication information technology, which can collect and process information. The most important of this is to collect information, through the collection and processing of information can simultaneously detect many information in real time. The Internet of things can be used better for some of the user's conditions, such as the history of the development of the surrounding things, the geographical location of the user and the weather forecast of the user's place, etc. Can carry on the comprehensive information collection and the display. This can better provide users with all kinds of necessary information and services. For other users feedback information, can also be understood by the user, so as to identify and distinguish. In this way, different users in all parts of the world can make personalized settings and services according to their own situation, so that users can feel the most satisfactory service and the most comprehensive information.

4. Results and Discussions

The Neural Network (NN) is proposed in this system to analyze the performance of tourism. The proposed system is an analysis based on the FPGA Xilinx software; this software shows the circuit is run and explained the voltage and current value of the circuit are consumed.

The proposed Neural Network (NN) based data mining work is actualized on the Vertex-2 Pro FPGA parameter are shown in table 1.

Figure 7 gives the performance examination of the proposed Neural Network (NN) with the standard technique. Compared with traditional PSO and SVM methods, the proposed Neural Network (NN) method delivered significant results for every working condition.

5. Conclusion

This work is a database for analyzing tourists' flow in collecting and processing tourism data, tourism flow, and scenic spots, including tourism and other statistical analysis, which is useful information for managing all scenic spots. We are proposing the method. The results show that this method can effectively analyze information on tourist flow and other behaviors through tourism data and analysis of scenic spots. It can provide big data support to reduce traffic pressure on tourist routes and facilitate tourist routes to reduce future traffic. Operation and management of scenic spots. Industry-academia mutual benefit cooperation has become a promising way to effectively overcome the above challenges related to data availability. This method of using big data ensures data availability to a large extent, reduces the cost of data for tourism research, and effectively solves and proposes real problems in the tourism industry. FPGA Xilinx software-based system does not provide.

Declaration of Competing Interest

We declare that we have no financial and personal relationships with other people or organizations that can inappropriately influence our work, there is no professional or other personal interest of any nature or kind in any product, service and/or company that could be construed as influencing the position presented in, or the review of the manuscript.

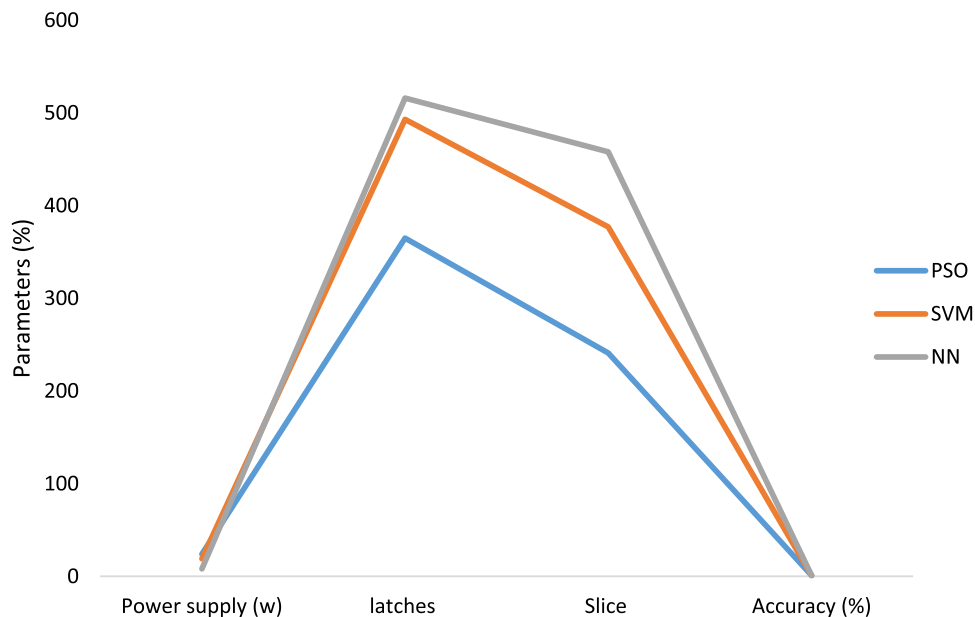

Figure 7. Performance of the proposed System

Reference

- [1] James Olmsted, Steve Mwangi, Hybrid Environment IoT-Mapping of Over-Tourism and Air Pollution in The azores Archipelago, in: Conference on Technologies for Sustainability, 2020.
- [2] Reynaldi Siwalete, Suyoto, "IoT-Based Smart Gallery to Promote Museum in Ambon, in: Conference on Smart Trends in Systems, Security and Sustainability, 2020.
- [3] Vallikannu Kavitha, Delay-aware concurrent data management method for IoT collaborative mobile edge computing environment, *Microprocessors and Microsystems* (2020).
- [4] Leandro Soares, James Harbin, Side-channel protected MPSoC through secure real-time networks-on-chip, *Microprocessors and Microsystems* (2019).
- [5] Saleh Alghamdi, Shopping and tourism for blind people using RFID as an application of IoT, *International Conference on Computer Applications & Information Security* (2019).
- [6] Roberto Girau, Matteo Anedda, Coastal Monitoring System based on Social Internet of Things Platform, *IEEE Internet of Things Journal* (2019).
- [7] LIN CHUN-CHENG, LIU WAN-YU, Three-Dimensional Internet-of-Things Deployment with Optimal Management Service Benefits for Smart Tourism Services in Forest Recreation Parks, *IEEE Access* (2019).
- [8] Subrahmanian Muthuraman, Mohammed Al Haziazi, Smart Tourism Destination – New Exploration towards Sustainable Development in Sultanate of Oman, in: *International Conference on Information Management*, 2019.
- [9] Sara Pouryousefzadeh, Reza Akbarzadeh, Internet of Things (IoT) systems in future Cultural Heritage, in: *International Conference on Internet of Things and Applications*, 2019.
- [10] Roberto Girau, Enrico Ferrara, Be Right Beach: A Social IoT system for sustainable tourism based on beach overcrowding avoidance, in: *Confs on Internet of Things*, 2018.
- [11] Xudong Guo, Tao Zeng, Fuzzy TOPSIS Approaches for Assessing the Intelligence Level of IoT-based Tourist Attractions, in: *IEEE Access*, 2018.
- [12] Sravani Challa, Mohammad Wazid, Secure Signature-Based Authenticated Key Establishment Scheme for Future IoT Applications, *IEEE Access* (2017).
- [13] Tien-Yin Chou, Yang-Tien Hsu, The Strategic Development and Spatial Information Applications of Smart Cities in Taiwan, in: *Pacific Neighborhood Consortium Annual Conference and Joint Meetings*, 2017.
- [14] Bishnu Prasad Gautam, Hiroyasu Asami, Regional Revival through IoT Enabled Smart Tourism Process Framework (STPF): A Proposal, in: *International Conference on Soft Computing and Intelligent Systems*, 2016.
- [15] Lu Li, Mei Rong, An Internet of Things QoE Evaluation Method based on Multiple Linear Regression Analysis, in: *International Conference on Computer Science & Education*, 2015.



Gao Haifeng, Man, Han nationality, 1989.02, People from Teng County, Guangxi, (International College) National Institute of Development Administration, PhD student, Guangxi University of Finance and Economics\assistant researcher, Graduate degree, Master of Engineering, research direction: Mainly engaged in tourism industry and tourism management research, Published 9 academic papers and 5 software copyrights.